

**ASSEMBLY INSTRUCTIONS**

1. Note Assembly Position & Orientation:  
Before disassembly, note insert carrier (4) and insulator (5) assembled position and orientation
2. Cable Stripping:  
Strip the cable according to the chart on the right side of this page.
3. Connector/Cable Preparation:  
Slide the bend relief (1), collet nut (2) and collet (3) onto the cable. If there is a shield, fold back around the collet (3).
4. Soldering:  
Solder the conductors to the contacts on the insulator (5).
5. Pre Assembly:  
Position the insert carrier (4) onto the insulator (5); use same assembly position and orientation as noted in Step 1 before disassembly.  
Push the collet (3) tab into the slot of the insert carrier (4). Ensure shield remains in place, cut away an excess shielding.
6. Finale Assembly:  
Push the pre assembly created above into the connector housing (6). The tab from the insert carrier (4) will align with slot inside the connector housing (6) which is located under the red dot. Note, some insert carriers (4) will not have a tab.  
With all the above inserted into the connector housing (6), screw on the collet nut (2).  
If using bend relief (1), a fix onto collet nut (2) at this time.

Recommend Cable Strip Lengths (mm)				
NorComp Series	Insulator Positions	A±0.2	B±0.5	C±0.5
820B Series	2, 3	3.0	7.0	13.0
	4, 5	3.0	7.0	13.0
	6, 7, 9	2.5	7.0	14.0
821B Series	2, 3	3.5	8.0	14.0
	4, 5	3.0	8.0	14.0
	6, 7, 8	3.0	8.0	14.0
	10, 14	2.5	8.0	16.5
822B Series	2	4.0	9.0	19.0
	3	3.5	9.0	19.0
	4, 6	3.5	9.0	18.0
	8, 10	3.0	9.0	17.0
	12, 14, 16, 19	3.0	9.0	17.0
	26	2.5	9.0	17.0

RoHS COMPLIANT

DO NOT SCALE FROM DRAWING



THESE DRAWINGS AND SPECIFICATIONS ARE THE PROPERTY OF NorComp AND SHALL NOT BE REPRODUCED, COPIED OR USED AS THE BASIS FOR THE MANUFACTURE OR SALE OF APPARATUS WITHOUT WRITTEN PERMISSION.

DRAWN:  
J. KADEL  
DATE:  
06/15/2023

**NorComp**

SCALE: NTS SHEET 1 OF 3 REV 0  
DWG NO. QUIK-LOQ ASSEMBLY INSTRUCTIONS

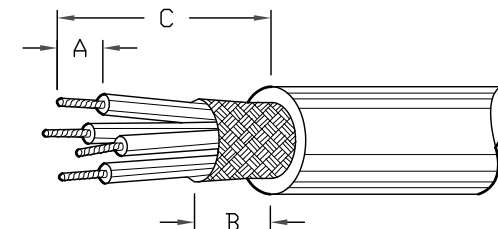
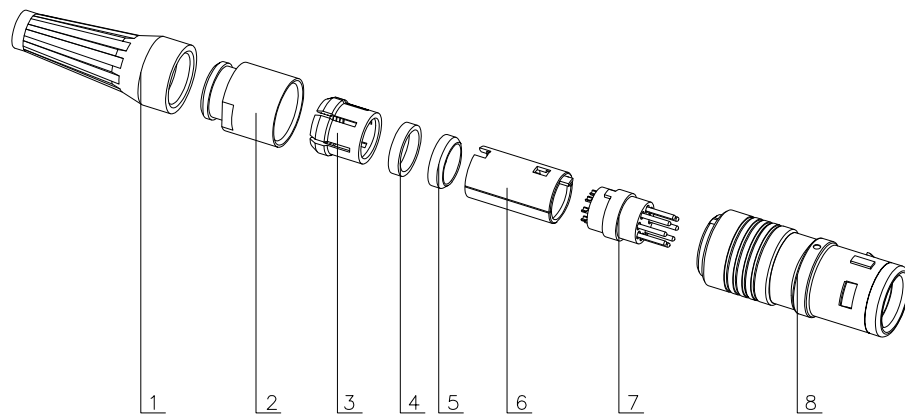

**ASSEMBLY INSTRUCTIONS**

1. Note Assembly Position & Orientation:  
Before disassembly, note insert carrier (6) and insulator (7) assembled position and orientation
2. Cable Stripping:  
Strip the cable according to the chart on the right side of this page.
3. Connector/Cable Preparation:  
Slide the bend relief (1), collet nut (2) and collet (3), gasket (4), earthing washer (5) onto the cable. If there is a shield, fold back around the collet (3).
4. Soldering:  
Solder the conductors to the contacts on the insulator (7).
5. Pre Assembly:  
Position the insert carrier (6) onto the insulator (7); use same assembly position and orientation as noted in Step 1 before disassembly.  
Push the gasket (4), earthing washer (5), collet (3) against the insert carrier (6), ensure tab of collet goes into the slot of the insert carrier (6).  
Ensure shield remains in place, cut away an excess shielding.
6. Finale Assembly:  
Push the pre assembly created above into the connector housing (8). The tab from the insert carrier (6) will align with slot inside the connector housing (8) which is located under the red dot. Note, some insert carriers (6) will not have a tab.  
With all the above inserted into the connector housing (8), screw on the collet nut (2).  
If using bend relief (1), a fix onto collet nut (2) at this time.

Recommend Cable Strip Lengths (mm)				
NorComp Series	Insulator Positions	A±0.2	B±0.5	C±0.5
820K Series	2, 3	3.0	6.0	8.0
	4, 5	3.0	6.0	8.0
	6, 7, 9	2.5	6.0	9.0
821K Series	2, 3	3.5	7.0	10.5
	4, 5	3.0	7.0	10.5
	6, 7	3.0	7.0	10.5
	14	2.5	7.0	13.0
822K Series	2	4.0	8.0	16.5
	3	3.5	8.0	16.5
	4, 6	3.5	8.0	15.5
	8, 10	3.0	8.0	14.5
	12, 14, 16, 19	3.0	8.0	14.5
	26	2.5	8.0	14.5

RoHS COMPLIANT

DO NOT SCALE FROM DRAWING



THESE DRAWINGS AND SPECIFICATIONS ARE THE PROPERTY OF NorComp AND SHALL NOT BE REPRODUCED, COPIED OR USED AS THE BASIS FOR THE MANUFACTURE OR SALE OF APPARATUS WITHOUT WRITTEN PERMISSION.

DRAWN:  
J. KADEL

DATE:  
06/15/2023

NorComp

SCALE: NTS SHEET 2 OF 3 REV 0

DWG NO. QUIK-LOQ ASSEMBLY INSTRUCTIONS

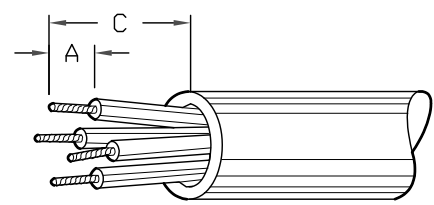
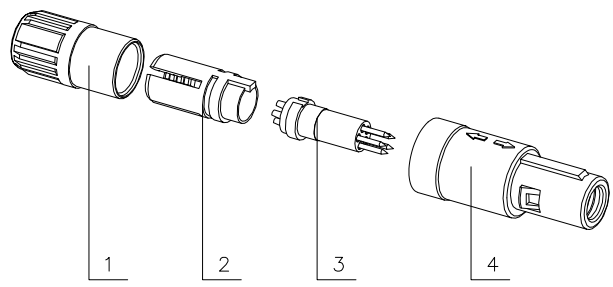

**ASSEMBLY INSTRUCTIONS**

1. Note Assembly Position & Orientation:  
Before disassembly, note insert carrier (6) and insulator (7) assembled position and orientation
2. Cable Stripping:  
Strip the cable according to the chart on the right side of this page.
3. Connector/Cable Preparation:  
Slide the collet nut (1) and collet (2) onto the cable.
4. Soldering:  
Solder the conductors to the contacts on the insulator (7).
5. Pre Assembly:  
Position the collet (2) onto the insulator (3); use same assembly position and orientation as noted in Step 1 before disassembly.
6. Finale Assembly:  
Push the pre assembly created above into the connector housing (4). The tab from the collet (3) will align with slot inside the connector housing (4).  
With all the above inserted into the connector housing (4), screw on the collet nut (1).

Recommend Cable Strip Lengths (mm)			
NorComp Series	Insulator Positions	A±0.2	C±0.5
8P1P Series	2, 3	4.0	14.0
	4, 5	3.0	13.0
	6, 7, 8, 9, 10, 14	2.5	12.5

RoHS COMPLIANT

DO NOT SCALE FROM DRAWING



THESE DRAWINGS AND SPECIFICATIONS ARE THE PROPERTY OF NorComp AND SHALL NOT BE REPRODUCED, COPIED OR USED AS THE BASIS FOR THE MANUFACTURE OR SALE OF APPARATUS WITHOUT WRITTEN PERMISSION.

DRAWN:  
J. KADEL  
DATE:  
06/15/2023

**NorComp**

SCALE: NTS SHEET 3 OF 3 REV 0  
DWG NO. QUIK-LOQ ASSEMBLY INSTRUCTIONS